

# SkyEye24AC User Manual

Version 2.1

Apr 2024

---



All materials related to this publication are subject to change without notice and its copyright totally belongs to ToupTek Photonics.

Please download the latest version from [touptek-astro.com](http://touptek-astro.com).

## Contents

<b>SkyEye24AC User Manual</b> .....	<b>1</b>
<b>1 Description and Features</b> .....	<b>2</b>
<b>2 SkyEye24AC Specifications and Performance</b> .....	<b>3</b>
2.1 Camera Specifications .....	3
2.2 Sony IMX410 Sensitivity .....	4
2.3 14Bit ADC and ROI.....	4
2.4 DDR3 Buffer.....	4
2.5 Binning .....	4
2.6 Conversion Gain Switch.....	4
2.7 Power and Cooling System for Precise Temperature Regulation.....	5
2.8 Zero Amp-Glow .....	5
2.9 Camera Performance Analysis.....	5
<b>3 Product Package and Connections</b> .....	<b>9</b>
3.1 Packing List .....	9
3.2 Camera Dimension and Its Mount.....	9
3.3 Camera Outline and Interface.....	10
3.4 Camera Mechanical Connection with Adapter .....	10
3.5 Camera Mechanical Connection with Lens .....	11
3.6 Camera Tilt Adjustment.....	12
3.7 Camera Electric Connection with Accessories .....	12
<b>4 SkyEye24AC and Its Software</b> .....	<b>14</b>
4.1 Application Installation .....	14
4.1.1 <i>User-friendly UI Design</i> .....	14
4.1.2 <i>Professional Camera Control Panel</i> .....	15
4.1.3 <i>Practical Functions with Good Results</i> .....	15
4.1.4 <i>Powerful Compatibility</i> .....	16
4.1.5 <i>Hardware Requirement</i> .....	16
4.2 SkyEye24AC and Dshow .....	16
4.3 SkyEye24AC and the 3 <sup>rd</sup> Party Software.....	16
4.3.1 <i>Support Software</i> .....	16
4.3.2 <i>ASCOM Platform</i> .....	16
4.3.3 <i>PHD Guiding</i> .....	17
4.3.4 <i>Nebulosity</i> .....	17
4.3.5 <i>MetaGuide</i> .....	17
4.3.6 <i>MAXIMDL</i> .....	17
4.3.7 <i>AstroArt</i> .....	17
4.3.8 <i>FireCapture</i> .....	17
4.3.9 <i>SharpCAP</i> .....	17
4.3.10 <i>Registax</i> .....	17
4.3.11 <i>AstroStack</i> .....	17
4.3.12 <i>DeepSky Stacker</i> .....	17
<b>5 FAQ</b> .....	<b>18</b>
<b>6 Sevice</b> .....	<b>19</b>

# 1 Description and Features

With full frame sensor, precise temperature regulation, ultra-low readout noise and zero amp-glow, The SkyEye24AC camera is mainly used for deep sky photo shooting. Its extraordinary performance and extensive usage will give you great astrophotography experience.

The features of SkyEye24AC are listed below:

- IMX 410 Color CMOS Sensor
- Resolution: 6064 x 4040
- 5.94  $\mu\text{m}$  Square Pixels
- 43.3mm Full Frame Optical Format
- 14-bit ADC
- 512 Mbyte Memory Onboard
- Precise Temperature Regulation
- Zero Amp-Glow
- G Sensitivity: 572.76mV with 1/30s
- Ultra-Low Noise: 1.95 to 4.48 e- (Low Noise Mode)
- Support Low Noise Mode/ High Frame Rate Mode (15.2 FPS at all Pixel Readout 8 bit)
- Support HCG Mode/ LCG Mode
- SNR Max: 50.2 dB (Low Noise Mode)
- Dynamic Range: 87.3 dB (Low Noise Mode)
- -30°C below ambient under short exposure/ -35°C under long exposure time (> 1s)

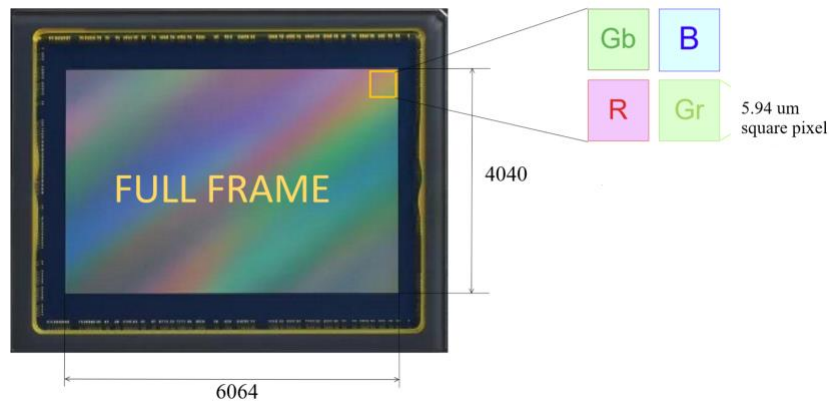

Figure 1 IMX410 Sensor

## 2 SkyEye24AC Specifications and Performance

### 2.1 Camera Specifications

Table 1 SkyEye24AC Technique Specifications.

Item	Specifications	
<b>Sensor</b>	Sony IMX410 Color CMOS	
<b>Diagonal</b>	43.3 mm	
<b>Image Resolution</b>	24 mega pixels, 6064× 4040	
<b>Pixel Size</b>	5.94μm × 5.94μm	
<b>Image Size</b>	36.02mm × 23.998mm	
<b>Max FPS at Resolution (USB 3.0)</b>	14bit	8bit
	8.0 FPS @ 6064*4040 19.5 FPS @ 3024*2012 64.3 FPS @ 2016*1342	16.0 FPS @ 6064*4040 38.8 FPS @ 3024*2012 114.6 FPS @ 2016*1342
<b>Max FPS at Resolution Low Noise (USB 3.0)</b>	14bit	8bit
	4.6 FPS @ 6064*4040 9.7 FPS @ 3024*2012 32.2 FPS @ 2016*1342	9.2 FPS @ 6064*4040 19.4 FPS @ 3024*2012 57.3 FPS @ 2016*1342
<b>Max FPS at Resolution (USB 2.0)</b>	14bit	8bit
	0.9 FPS @ 6064*4040 3.7 FPS @ 3024*2012 8.3 FPS @ 2016*1342	1.8 FPS @ 6064*4040 7.4 FPS @ 3024*2012 16.5 FPS @ 2016*1342
<b>Max FPS at Resolution Low Noise (USB 2.0)</b>	14bit	8bit
	0.4 FPS @ 6064*4040 2.5 FPS @ 3024*2012 5.8 FPS @ 2016*1342	0.8 FPS @ 6064*4040 5.0 FPS @ 3024*2012 11.6 FPS @ 2016*1342
<b>Shutter Type</b>	Rolling Shutter	
<b>Exposure Time</b>	0.1ms – 3600s	
<b>Gain</b>	1x – 150x	
<b>SNR</b>	50.2 dB	
<b>Dynamic Range</b>	87.3 dB (Low Noise Mode)	
<b>Read Noise (LCG)</b>	4.48 – 1.95 e-	
<b>Read Noise (HCG)</b>	0.68 - 0.3 e-	
<b>QE Peak</b>	>80%	
<b>Full Well</b>	104ke- (20ke- @HCG)	
<b>ADC</b>	14bit	
<b>DDR3 Buffer</b>	512MB (4Gb)	
<b>Connection Port</b>	USB3.0/USB2.0	
<b>Camera Adaptor</b>	M54 × 0.75	
<b>Protect Windows</b>	IR CUT	
<b>Spectral Range</b>	380-690nm (with IR-cut Filter)	
<b>Capture/Control SDK</b>	Windows/Linux/macOS/Android Multiple Platform SDK(Native C/C++, C#/VB.NET, Python, Java, DirectShow, Twain, etc.)	
<b>Recording System</b>	Still Picture and Movie	
<b>Camera Dimensions</b>	Diameter 89 * Height 103 (mm)	
<b>Camera Weight</b>	0.718kg	
<b>Back Focus Distance</b>	17.5mm	
<b>Cooling:</b>	Two stage TEC	

<b>Effective Cooling Temp:</b>	-30°C below ambient under short exposure/ -35°C under long exposure (> 1s)
<b>Supported OS</b>	Microsoft® Windows® XP / Vista / 7 / 8 /10 (32 & 64 bit) OSx(Mac OS X) Linux

## 2.2 Sony IMX410 Sensitivity

The sensor G sensitivity of SkyEye24AC is 572.76mV with 1/30s. Its spectral sensitivity is shown in Figure 2

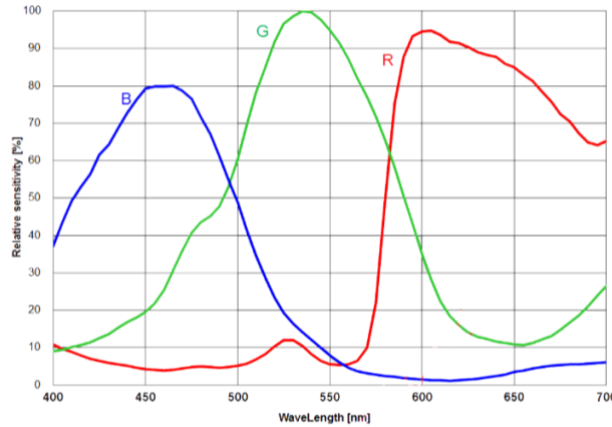

Figure 2 IMX410 Sensitivity Spectral Characteristic

## 2.3 14Bit ADC and ROI

The SkyEye24AC has built in 14bit ADC. It also has 12bit output mode for hardware binning and smaller resolution. The camera also supports hardware ROI, and the smaller the ROI size is, the faster frame rate is.

Table 2 SkyEye24AC Frame Rate at Different Resolution/Data Bit/Data Transfer(USB3.0/ USB2.0)

Resolution	FPS	Bit & Interface		14Bit ADC		8Bit ADC	
		USB3.0	USB2.0	USB 3.0	USB 2.0		
6064*4040		8.0	0.9	16.0	1.8		
3024*2012		19.5	3.7	38.8	7.4		
2016*1342		64.3	8.3	114.6	16.5		
6064*4040 Low Noise		4.6	0.4	9.2	0.8		
3024*2012 Low Noise		9.7	2.5	19.4	5.0		
2016*1342 Low Noise		32.2	5.8	57.3	11.6		

## 2.4 DDR3 Buffer

SkyEye24AC camera has a 512MB (4Gb) DDR3 buffer, which helps maintain the stability of data transmission, and effectively reducing the amp-glow caused because image data can be temporarily buffered without being sent hastily to the receiver.

## 2.5 Binning

The SkyEye24AC supports digital binning from 1×1 to 8×8 in either stacking or averaging method, and hardware binning from 1×1 to 3×3 in averaging method. Hardware pixel binning is much faster than software binning.

## 2.6 Conversion Gain Switch

SkyEye24AC supports HCG and LCG mode switch. Under HCG mode, the readout noise could reach 0.3 e- at maximum

gain setting.

## 2.7 Power and Cooling System for Precise Temperature Regulation

The cooling system of SkyEye24AC is two-stage [Thermoelectric Cooling](#) (TEC) with controllable electric fan assisting heat dissipation. The working temperature can be regulated to specific number, and effective temperature drop can be  $-35^{\circ}\text{C}$  from ambient temperature. Such efficient cooling system guarantees the stability of ultra-low noise mode and quality of the camera image.

The TEC system is controlled by PID algorithm, which allows the TEC to be precisely regulated towards the target temperature with 0.1C deviation.

## 2.8 Zero Amp-Glow

The SkyEye24AC has been carefully designed and is able to achieve zero amp-glow photo shooting. Figure 3 Amp-glow. and Figure 4 show the different cameras at  $20^{\circ}\text{C}$  and 5-minute exposure time with and without amp-glow. One can find that SkyEye24AC captured image has zero amp-glow.

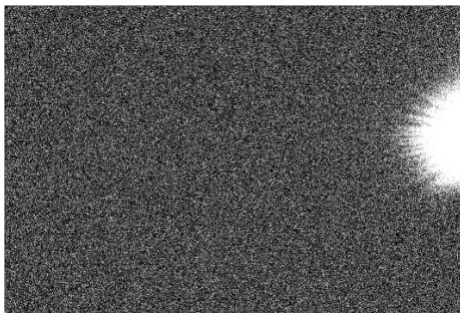

Figure 3 Amp-glow.

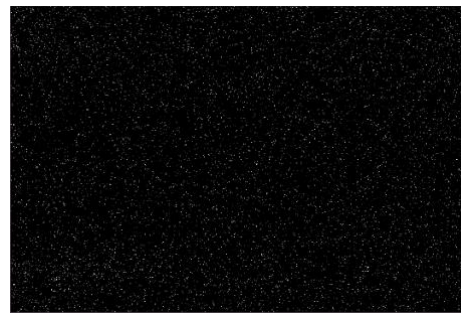

Figure 4 Zero amp-glow.

## 2.9 Camera Performance Analysis

Camera performance can be evaluated with [e-/ADU](#), [Read Noise](#), [Full Well](#) and [Dynamic Range](#).

[e-/ADU](#): The sensors found in cameras used for vision applications have pixels that convert incoming photons into electrons. Gain on a CCD /CMOS camera represents the conversion factor from electrons (e-) into digital counts, or [Analog-Digital Units \(ADUs\)](#). Gain is expressed as the number of electrons that get converted into a digital number, or electrons per [ADU \(e-/ADU\)](#).

[Read Noise](#): Read Noise is the most important reference to measure the performance of a camera. Lower read noise usually means better SNR and better quality of image. [Read Noise](#) is created within the camera electronics during the readout process as the electrons are subjected to the analog to digital conversion, amplification and processing steps that enable an image to be produced.

[Full Well](#): The electrons are held in each pixel and are converted into electrical charge which can be measured to show the amount of light that has fallen on each pixel. The maximum electrical charge possible is termed "[full well capacity](#)". Under the same conditions such as noise and A/D converter quality, the greater full well capacity a sensor has, the wider dynamic range the sensor has. As there is a limit to the depth to which pixels can be made, the full well capacity is often proportional to the frontal area of the light gathering element of the pixel.

[Dynamic Range](#) is the ratio between the maximum output signal level and the noise floor at minimum signal amplification (noise floor which is the RMS (root mean square) noise level in a black image). The noise floor of the camera contains sensor readout noise, camera processing noise and the dark current shot noise. [Dynamic range](#) represents the camera's ability to display/reproduce the brightest and darkest portions of the image and how many variations in between. This is technically intra-scene dynamic range. Within one image there may be a portion that is in complete black and a portion that is completely saturated.

For the SkyEye series camera, the [Gain Value](#) is in xxx% mode. Here xxx is used as the x axis ([Gain Value](#)) for the description of the camera performance

$$Rel\ Gain(dB) = 20 * \log_{10}[xxx(Gain\ Value)/100]$$

$$xxx(Gain\ Value) = 100 \times 10^{(Rel\ Gain(dB)/20)}$$

SkyEye24AC has a significantly low read noise: 4.48 – 0.68e-. It is more impressive that this camera comes with low noise mode, which means users could get even lower readout noise by selecting low noise mode while the frame rate only drops a little as sacrifice.

Camera setting used for performance analysis in HCG mode is as follow:

- Full resolution
- RAW 14 Bit mode
- Temperature: -5°C

Table 3 Sensor Analysis Data in HCG Mode

Sensor Analysis Data												
Gain Value	100	158	251	398	630	1000	1584	2511	3981	6309	10000	15000
Rel Gain (dB)	0.00	4.17	8.17	12.16	16.03	20.12	24.09	28.02	32.02	35.95	39.78	42.56
e-/ADU	1.22	0.77	0.49	0.31	0.2	0.12	0.08	0.05	0.03	0.02	0.01	0.01
Read Noise Normal (e-)	0.68	0.62	0.62	0.61	0.59	0.57	0.55	0.52	0.49	0.42	0.39	0.3
Full Well (ke-)	20	12.7	8.81	5.05	3.2	2.02	1.28	0.8	0.51	0.32	0.21	0.15
DR (stop)	14	14	13.66	13.02	12.41	11.78	11.18	10.61	10.02	9.54	9.08	8.97

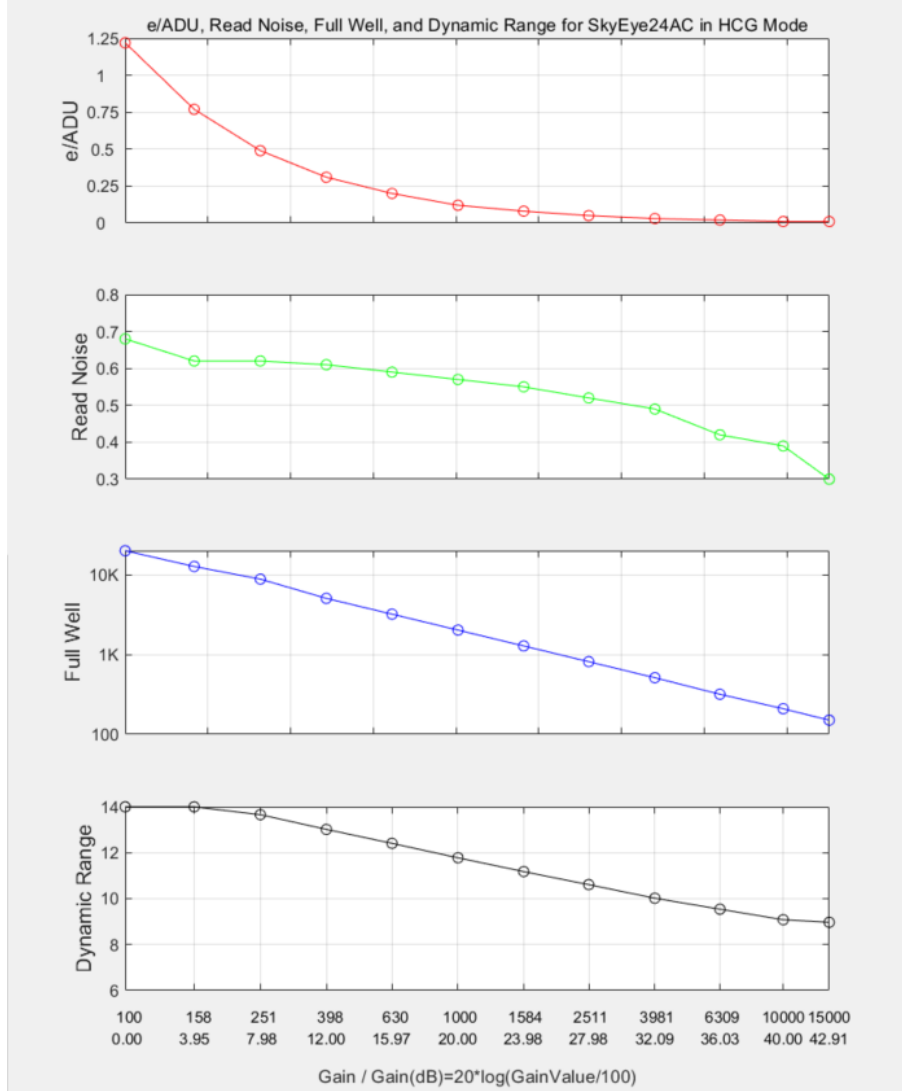

Figure 5 e-/ADU, Read Noise, Full Well, Dynamic Range for SkyEye24AC



Camera setting used for performance analysis in LCG mode is as follow:

- Full resolution
- RAW 14 bit mode
- Temperature: -5 °C

Table 4 Sensor Analysis Data in LCG Mode

Sensor Analysis Data												
<b>Gain Value</b>	100	158	251	398	630	1000	1584	2511	3981	6309	10000	15000
<b>Rel Gain</b>	0.00	3.95	7.97	11.96	15.93	19.93	23.92	27.87	31.92	35.87	39.78	42.69
<b>e-/ADU</b>	6.33	4.02	2.53	1.6	1.01	0.64	0.4	0.26	0.16	0.1	0.06	0.05
<b>Read Noise (e-)</b>	4.48	4.12	4.3	4.16	3.96	3.8	3.62	3.5	3.36	3.14	2.55	1.95
<b>Full Well(ke-)</b>	104	65.8	41.5	26.2	16.6	10.5	6.61	4.19	2.63	1.67	1.06	0.76
<b>DR(stop)</b>	14	13.96	13.24	12.62	12.03	11.43	10.83	10.22	9.61	9.05	8.70	8.61

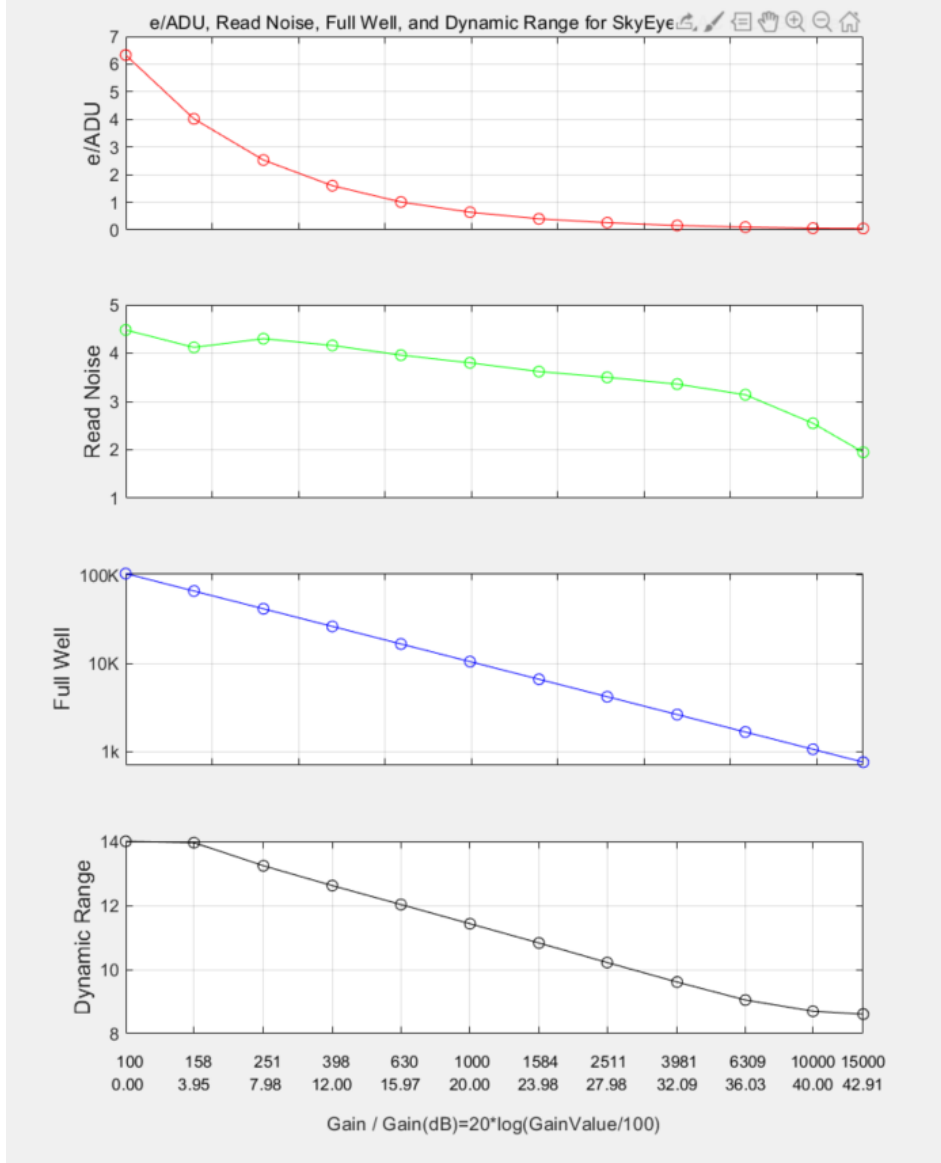

Figure 6 e-/ADU, Read Noise, Full Well, Dynamic Range for SkyEye24AC

### 3 Product Package and Connections

#### 3.1 Packing List



Figure 7 Packing Information of SkyEye24AC

Table 5 SkyEye24AC Packing List

Standard Package	
A	3-A safety equipment case: L:26.2cm W:24.0cm H:12.4cm (1pcs, 3.9Kg/ box)
B	SkyEye camera (M54F×0.75 mount)
C	Power adapter: input: AC 100~240V 50Hz/F60Hz, output: DC 12V 3A
D	High-Speed USB3.0 A male to B male gold-plated connectors cable /1.5m
E	CD (Driver & utilities software, Ø12cm)
F	Hex wrench H 2.0
G	M54M-M48F 21mm extender
H	M48M-M48F 16.5mm extender
I	M48M-M42F adapter

#### 3.2 Camera Dimension and Its Mount

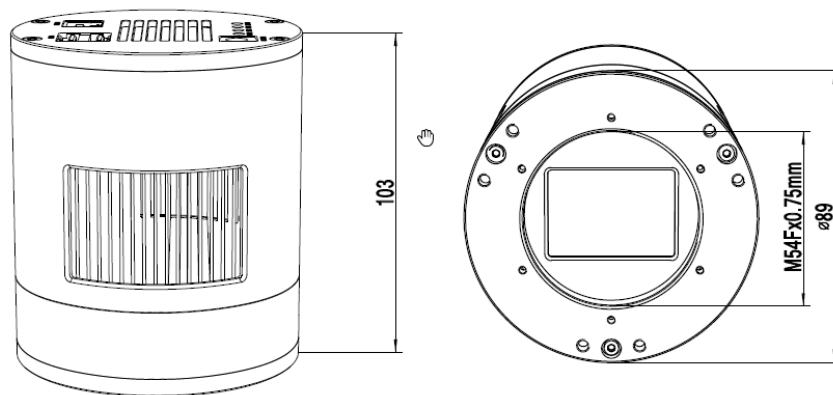

Figure 8 Dimension and Mount of SkyEye24AC

Table 6 Dimension and Mount of SkyEye24AC

Item	Specification
Diameter	Ø89mm
Height	103mm
Mount	M54Fx0.75mm

### 3.3 Camera Outline and Interface

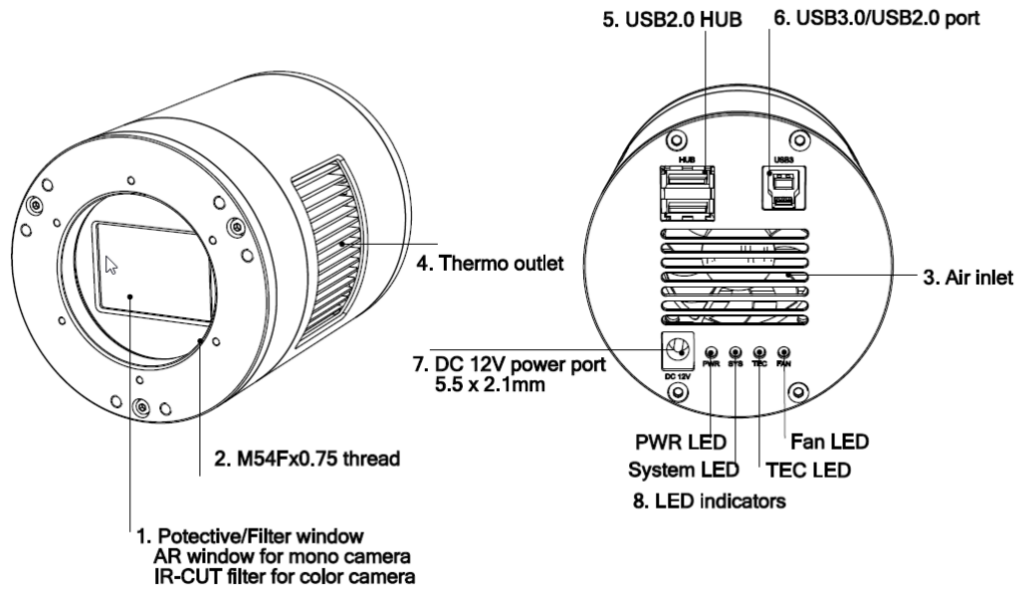

Figure 9 Camera Outline and Interface.

Table 7 Camera Outline and Interface List

Item	Specification
1	Protective window, 39 × 27 × 1.1mm, AR window for mono camera, IR-CUT for color camera
2	M54F × 0.75 thread
3	Air inlet
4	Thermo outlet
5	USB 2.0 HUB
6	USB 3.0/ USB 2.0 port
7	DC 12V 3A power port, 5.5 × 2.1mm
8	LED indicators: 1) Power LED. 2) System LED. 3)TEC LED. 4)Fan LED

### 3.4 Camera Mechanical Connection with Adapter

The SkyEye24AC can be connected to a telescope with proper adapter, or the camera lens. The most common adapters are already included in the package, but we also provide some specific adaptors based on the requirement.

The female flange to the sensor is 17.5mm. User can make it to 55mm back focus distance with the 21mm and 16.5mm extender included in the camera package. Please check Figure 10 for details.

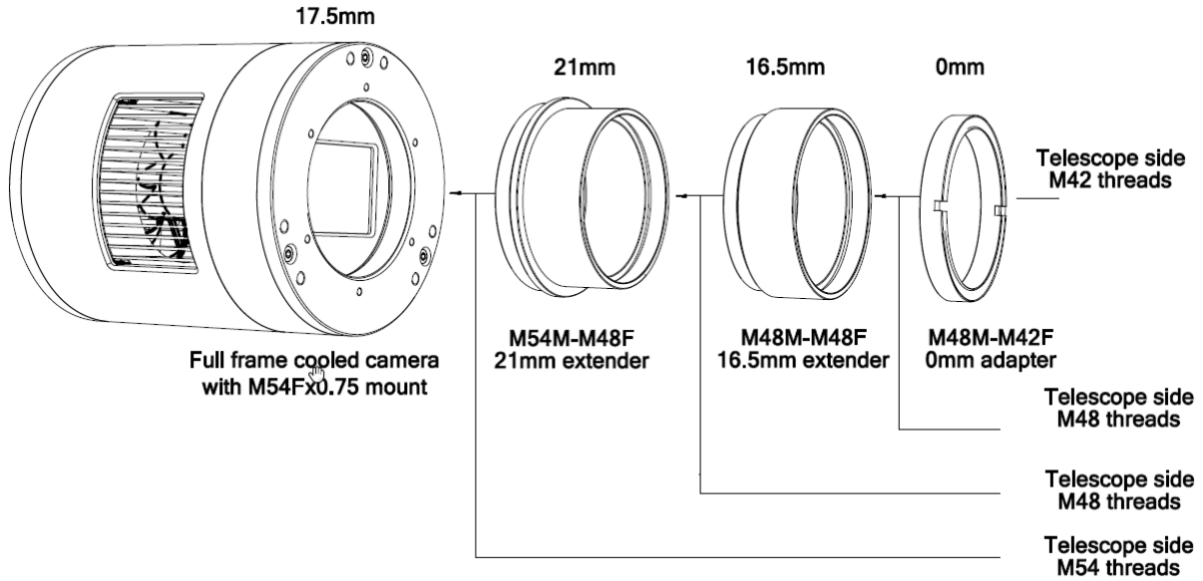

Figure 10 The Connection of the SkyEye Camera and Adapter

Table 8 Camera and Its Adapter Connections

Item	Specification
Back Focal Distance	Protective window, 39 × 27 × 1.1mm, AR window for mono camera, IR-CUT for color camera
M54M-M48F 21mm extender	21mm with M48Fx0.75mm for M48M × 0.75 telescope
M48M-M48F 16.5mm extender	16.5mm with M48Fx0.75mm for M48M × 0.75 telescope
M48M-M42F 0mm adapter	0mm with M48Fx0.75mm for M42F × 0.75 telescope

### 3.5 Camera Mechanical Connection with Lens

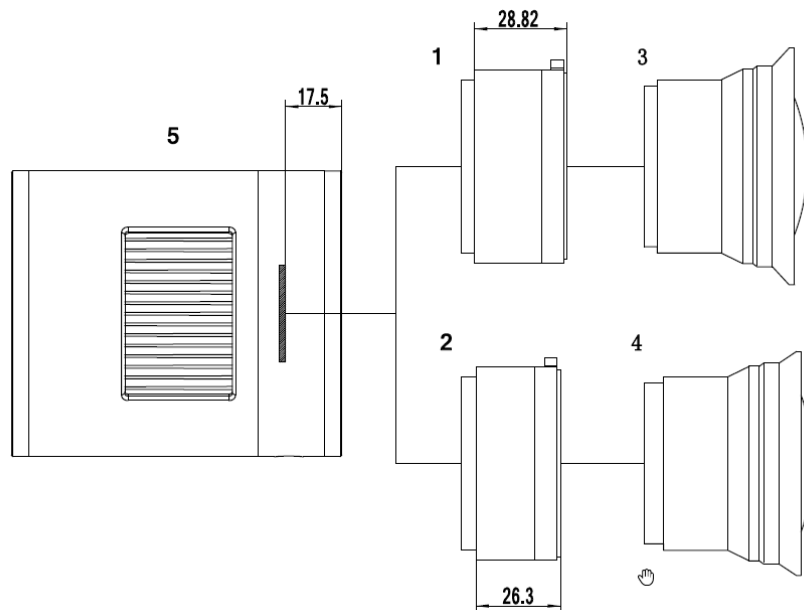

Figure 11 Nikon F/Canon EF Lens with SkyEye Camera

Table 9 Camera and Lens Connection

Item	Specification
1	Nikon F-M54 adapter
2	EOS EF-M54 adapter
3	Nikon F-Mount lens
4	Canon EF-Mount lens
5	SkyEye camera with M54Fx0.75 mount

### 3.6 Camera Tilt Adjustment

SkyEye24AC has the tilt adjustment ability. There are 3 sets of screws that can be used to tilt the sensor, making it parallel with the telescope, two screws per set for screw in /out.

One can refer to below:

Table 10 Camera Tilt Adjustment

Steps	Operations
1	Take a starred image with the camera, user can easily find out the tilt part in the image through the software(such as siril、ccdinspector、astap), and then adjust one or more sets of flange adjustment screws on the camera corresponding to the imaging result.
2	Take another image after the sensor tilt adjustment, and compare it with the previous one in the software. If the tilt issue is reduced, that means the adjustment is correct. Otherwise, the adjustment is wrong.
3	Repeat step 2 until the stars in all corners are perfect.

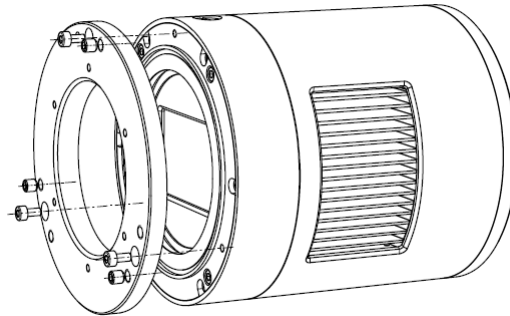

Figure 12 Tilt Adjustment

### 3.7 Camera Electric Connection with Accessories

On the back side of SkyEye24AC, there are 3 connection ports: DC 12V/3A power port, USB3.0/ USB2.0 port and USB-HUB.

Due to the significantly larger power consumption of IMX410, SkyEye24AC (including the cooling system) is now booted up only by 12V/3A power supply. USB3.0 no longer works as a power source but only as a data communication method. The USB-HUB provides connection with other devices, which allows user to avoid the mess of cable management. Once another device is connected through the USB-HUB, it will be connected to PC device through the USB3.0/USB2.0 port.

Table 11 Camera Electric Connection

Item	Specification
USB3.0/USB2.0 port	To computer with USB3.0/USB2.0 cable
USB HUB for accessories	To filter wheel with USB2.0 cable
	To guiding camera with USB 2.0 cable
Power port	DC12V/3A

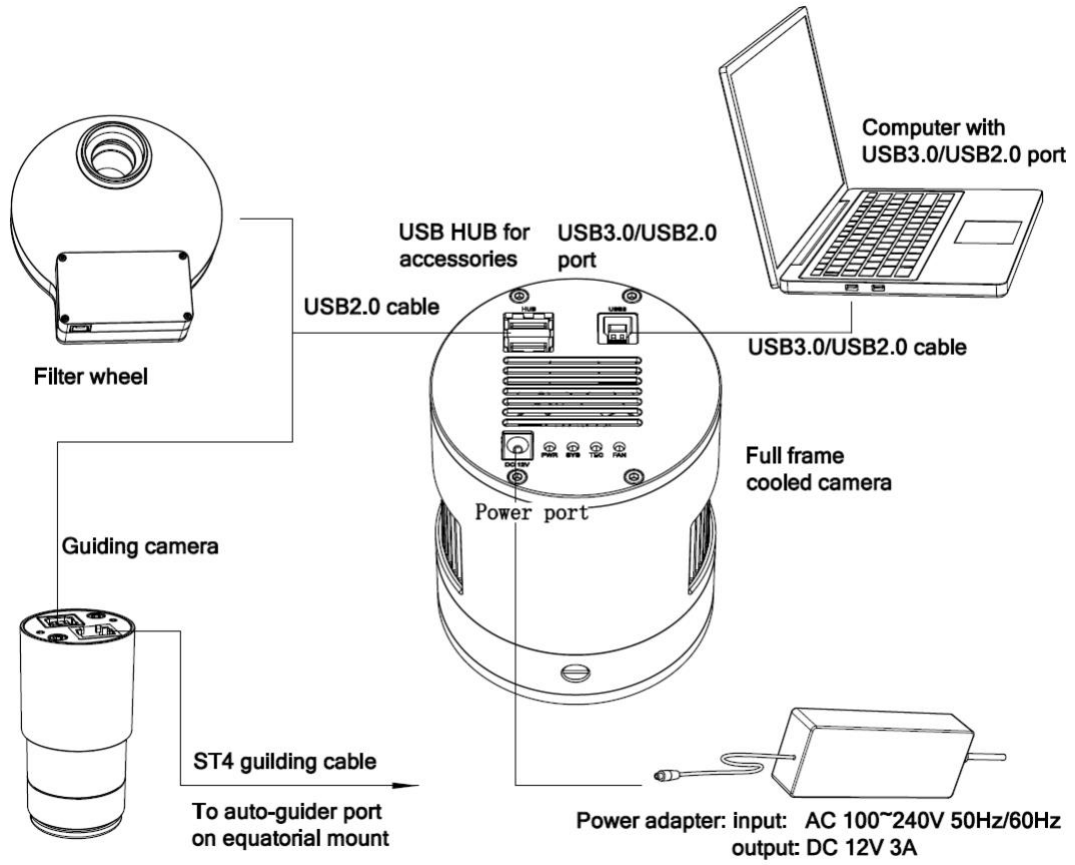

Figure 13 Camera Electric Connection

## 4 SkyEye24AC and Its Software

### 4.1 Application Installation

For software, customers are welcomed to go to our software website: <https://toupTek-astro.com/downloads/>, to download the latest ToupSky. The SkyEye can also be used with ASCOM, DirectShow SDK. If the third-party software is compatible with these SDK, customers can also download the software driver from our website and install the drivers into the third-party software.

ToupSky is ToupTek astronomy camera's Windows application. ToupSky is a professional software integrated with camera control, image capture & process, image browse, and analysis functions. ToupSky was born with the following features:

Windows:

- x86: XP SP3 or above; CPU supports SSE2 instruction set or above
- x64: Win7 or above

Features

- Fully control of the camera
- Trigger mode and video mode support (raw format or RGB format)
- Automatic capture and quick record function
- Multi-language support
- Hardware ROI and digital binning function
- Extensive image processing functions, like image stitching, live stacking, flat field correction, dark field correction, etc.

Supported Camera:

- All ToupTek astronomy cameras

#### 4.1.1 User-friendly UI Design

- Well-arranged menus and toolbars ensure quick operating;
- The unique design of 3 sidebars -- Camera, Folders, Undo/Redo are orderly classified;
- Convenient operating method (Double click or right-click context menu) as much as possible;
- Detailed help manual;

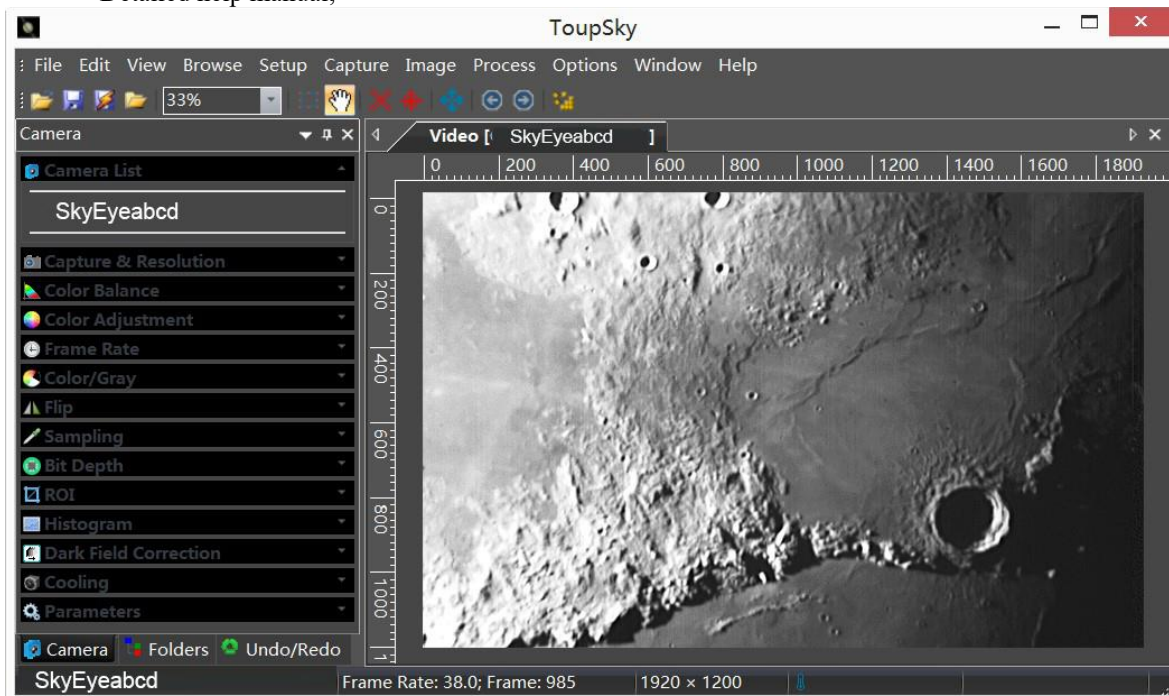

Figure 14 ToupSky Video Window

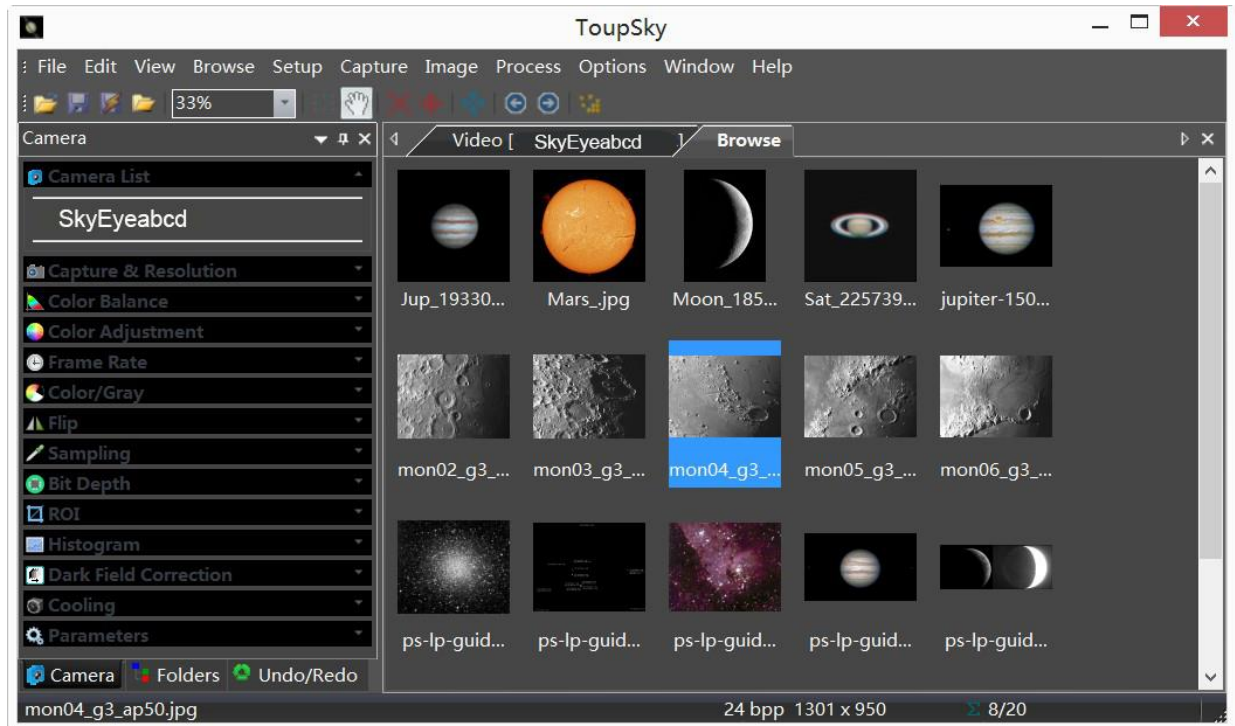

Figure 15 ToupSky Browse Window

#### 4.1.2 Professional Camera Control Panel

Capture & Resolution	Set the live and snap resolution and snap the image or record video;
Exposure & Gain	Auto exposure (exposure target preset) and manual exposure (exposure time can be inputted manually); Up to 5 times gain;
Color Balance	Advanced single-click intelligent white balance setting, temperature and tint can be manually adjusted;
Color Adjustment	Hue, saturation, brightness, contrast, gamma initialization adjustment;
Frame Rate	Adjustment of frame rate available for different computer configurations;
Flip	Check the "horizontal" or "vertical" option to correct the sample direction;
Sampling	Bin mode can obtain low noise video stream; Skip mode obtains sharper and smoother video stream. Support video stream histogram extension, Negative and positive switching, Gray calibration, Clarity factor for focusing etc.
Bit Depth	Switch between 8 bits and 12 bits. 8 bits is the basic Windows image format. 12bits will have higher image quality but moderate FPS.
ROI	ROI, Region of interest. This function can set the ROI on the video window. When the ROI group was expanded, a dotted rectangle with "Handles" will appear around the video window that will let you alter the ROI. Use mouse button to adjust the ROI size. If ROI is ok, click Apply will set the video to ROI size, Defaults will return to the original size.
Dark Field Correction	To Enable the Dark Field Correction, one should capture the dark field image first. After the images are captured, the Enable button will be clickable. Checking the Enable button will enable the Dark Field correction. Unchecking it will disable the Dark Field Correction.
Cooling	Set the TE-Cooling target temperature and set the fan On/Off;
Parameters	Load, save, overwrite, import, export self-defined parameters of camera control panel (including calibration information, exposure and color setting information);

#### 4.1.3 Practical Functions with Good Results

Video functions	Various professional functions: Video broadcast; Time lapse capture; Video record; Video stream grid; Image stitch; Video scale bar, date etc.
Image Processing and Enhancement	Control and adjust image by denoise, sharpen, color toning deinterlace, all kinds of filtering algorithm and mathematical morphology algorithm, range, binary, pseudo color, surface plot and line profile ital..
Image Stacking	Image stacking adopts advanced image matching technology. With the recorded video, regardless of shifting, rotation, scaling, the high-fidelity image can be stacked to decrease the image noise.



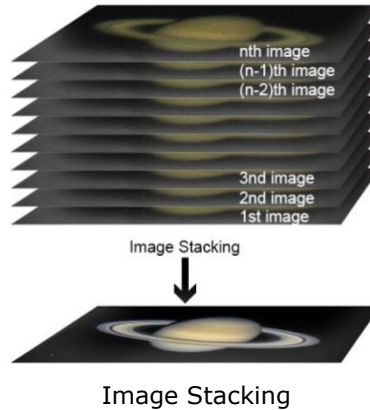

#### 4.1.4 Powerful Compatibility

Video Interface	Support Twain, DirectShow, SDK Package (Native C++、C#/VB.NET)
Operating System	Compatible with Microsoft® Windows® XP / Vista / 7 / 8 / 10 (32 & 64 bit), Mac OSX, Linux
Language Support	Unlimited language support, currently available in Simplified Chinese, Traditional Chinese, English, Russian, German, French, Polish and Turkish

#### 4.1.5 Hardware Requirement

PC Requirements	CPU: Intel Core 2 2.8GHz or higher
	Memory:2GB or more
	USB port: USB3.0/USB2.0 port
	Display:17" or larger
	CD-ROM

## 4.2 SkyEye24AC and Dshow

ToupTekDshowAstroSetup (Click the left blue link to download)

DshowAstro is an interface driver providing Dshow standard support for ToupTek USB astronomy camera

Supported OS: Windows:

- x86: XP SP3 or above; CPU supports SSE2 instruction set or above
- x64: Win7 or above

Supported Camera:

- All ToupTek astronomy cameras

## 4.3 SkyEye24AC and the 3<sup>rd</sup> Party Software

### 4.3.1 Support Software

No.	Software	Version	WDM	ASCOM	Native
1	PHD Guiding	2.3.0(2014)	√	√	√
2	Nebulosity	3.2.2(2014)	√	×	/
3	MaxIm DL	5.23(2013)	√	×	/
4	SharpCap	2.1(2014)	√	×	/
5	MetaGuide	5.2.0(2014)	√	/	/
6	FireCapture	2.4.05(2014)	√	/	/
7	Astroart	5.0(2014)	√	×	/

### 4.3.2 ASCOM Platform

All AstroCam telescope camera drivers request to install ASCOM platform, free.

<http://www.ascom-standards.org/index.htm>

You can download the ASCOM package from : <http://ascom-standards.org/Downloads/Index.htm>

### **4.3.3 PHD Guiding**

A popular free guide software: <http://openphdguiding.org/>

ToupTek's telescope camera support Native/ASCOM/WDM driver to run the video.

### **4.3.4 Nebulosity**

A popular cooled camera control/image process software directly supported via ASCOM.

### **4.3.5 MetaGuide**

Autoguiding software with novel method to avoid the atmospheric agitation. The latest version support GCMOS01200KPB and the guide port: <http://www.astrogeeks.com/Bliss/MetaGuide/>

### **4.3.6 MAXIMDL**

Famous full functional CCD Control/Image Process software. Popular used in US.

### **4.3.7 AstroArt**

Famous full functional CCD Control/Image Process software. Popular used in Europe.

### **4.3.8 FireCapture**

Great free planetary capture software. Support part of AstroCam series telescope camera.

### **4.3.9 SharpCAP**

A nice free planetary capture software support WDM cameras includes AstroCam series telescope camera.

### **4.3.10 Registax**

A popular free planetary stacking and processing software.

### **4.3.11 AstroStack**

A planetary stacking and process software.

### **4.3.12 DeepSky Stacker**

A free deep sky image stack and process software.

## 5 FAQ

IMX410 sensor might display image with uneven shading, which is decreasing horizontally. According to Sony, IMX410 sensor allows Horizontal Dark Shading smaller than 4.5 LSB. There are 3 possible reasons behind this characteristic.

First, due to the full frame size of the sensor, the internal circuit logic is more complicated, which makes much more difficult to supply identical power. In this case, due to the large size of full frame, Sony, after evaluation, determined this specification within the range of 4.5 LSB, which does not affect the image quality, so that the yield rate of this sensor and mass production on the assembly line could be guaranteed.

Second, due to the limitation of semiconductor manufacturing equipment, sensor with frame size larger than APS will be divided in to 2 or more parts in order to receive exposure process. This will inevitably cause a segment gap at the stitch position of 2 different exposure parts, and it is the main reason that large frame sensor's horizontal dark shading is more obvious.

Third, due to the different batches of mass production, although the sensors' specifications are all within the predetermined range, products of different batches will have different deviation.

## **6 Service**

For software upgrades, please refer to “Download” on our official website: <https://ToupTek-astro.com/>

For customers who purchase the cameras from local dealer, please contact your dealer for more inquiry.

For technical support, please contact e-mail address: [astro@ToupTek.com](mailto:astro@ToupTek.com)