

ToupTek OAG User Manual

Version 1.0

Jul 2023

All materials related to this publication are subject to change without notice and its copyright totally belongs to ToupTek Photonics.

Please download the latest version from toupTek-astro.com

Contents

ToupTek OAG User Manual	1
1 Description and Features	3
2 OAG Operating guide	4
2.1 Compatibility with guiding camera	4
2.2 Compatibility with telescope.....	4
2.3 Compatibility with main imaging camera	4
2.4 Connection to the telescope.....	4
2.5 Please Note	4
3 Assembly guide	5
3.1 Connect OAG to guiding camera	5
3.2 Connect extender to camera	7
3.3 Connect OAG to extender	8
3.4 Connect thread adapter (connect to telescope) to OAG	9
3.5 Adjust prism position	10
3.6 Focus adjustment.....	10
4 ToupTek OAG Mechanical Diagram	11
5 ToupTek OAG recommended Connection methods	13

1 Description and Features

ToupTek's Off-Axis Guider (OAG) allows user to guide the telescope to obtain sharp, round stars by guiding in front of filters using unfiltered light in the same optical path as the main imaging camera. OAG helps overcome non-synchronous distortion and provides higher guiding accuracy.

The features of ToupTek OAG are listed below:

- Connection (to the telescope): M48, M54, M68 based on customer's choice.
- Connector (at camera end): M54 x 0.75 (with 20mm extender included)
- Prism size (mm) 10 x 10
- Thickness: 17.5mm
- 6 mm adjustable focus travel distance.
- Compatible with all guiding cameras, whose body diameter is around 31mm.
- Compatible with telescopes with adapter's diameter within 80mm.



Figure 1 back and front of OAG

2 OAG Operating guide

2.1 Compatibility with guiding camera

For guiding, ToupTek OAG is compatible with all ToupTek GPCMOS series and G3M series guiding camera. ToupTek OAG is also compatible with guiding cameras whose body's diameter is within 30mm.

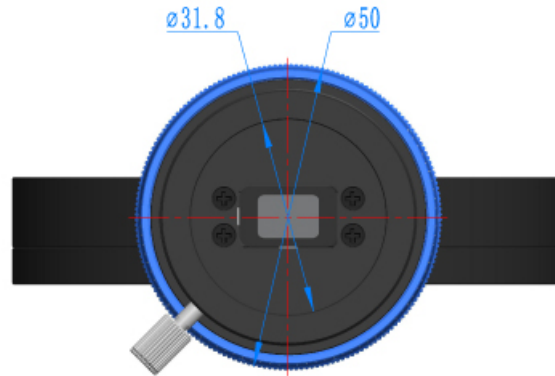

Figure 2 guiding camera adapter interface

2.2 Compatibility with telescope

Considering the 10x10 mm prism size, we don't recommend you use ToupTek OAG with telescopes whose clear aperture is smaller than M48.

2.3 Compatibility with main imaging camera

Yet it is recommended to use ToupTek OAG with ToupTek Filter Wheel (AFW), and with all ATR3CMOS series cameras, SkyEye series cameras and G3CMOS series cameras. The large clear aperture supports up to full-frame cameras without vignetting.

2.4 Connection to the telescope

ToupTek OAG offers a choice in one of the M48, M54, M68 thread adapters, connected to the telescope.

2.5 Please Note

While adding ToupTek OAG into your optical train, please make sure the prism won't block the camera sensor.

You can use the guiding screw to adjust the guiding camera's focus length. Please make sure the distances from the prism to the main camera and to the guide camera are the same. To ensure the result, it is better to do this during the daytime for the adjustment will be very difficult at night.

3 Assembly guide

3.1 Connect OAG to guiding camera

First, align the prism direction to sensor direction of guiding camera. Both long sides need to be paralleled.



Insert the guiding camera into OAG and tighten the top first screw to lock the guiding camera.



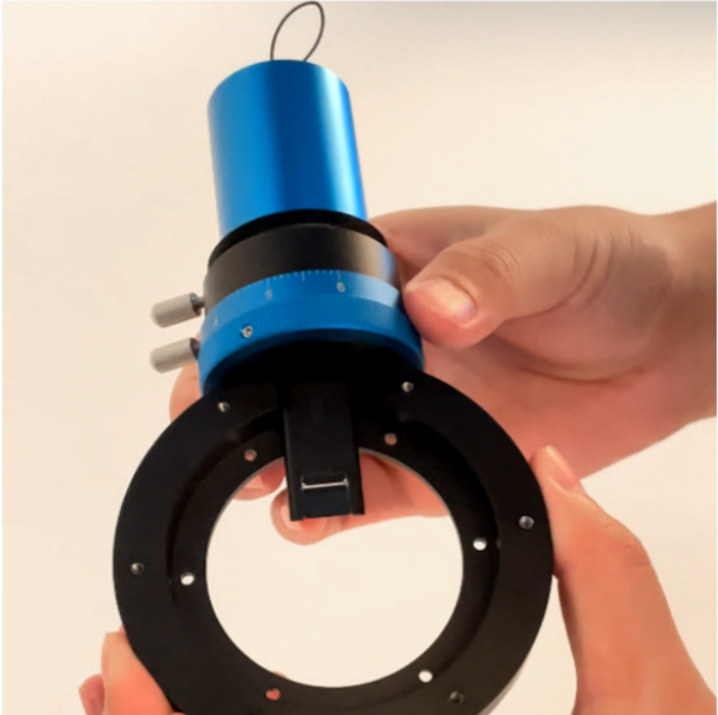

3.2 Connect extender to camera

Locate the 6 screw holes on the camera's adapter and put the 6 M2.5*20 screws through the extender and insert them into the holes on the camera.

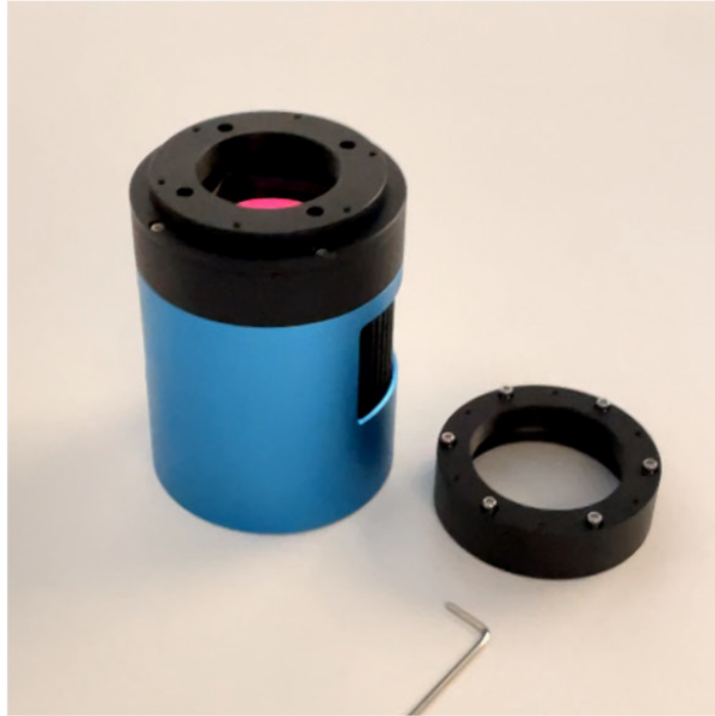

Tighten the screws to lock the extender on the camera.

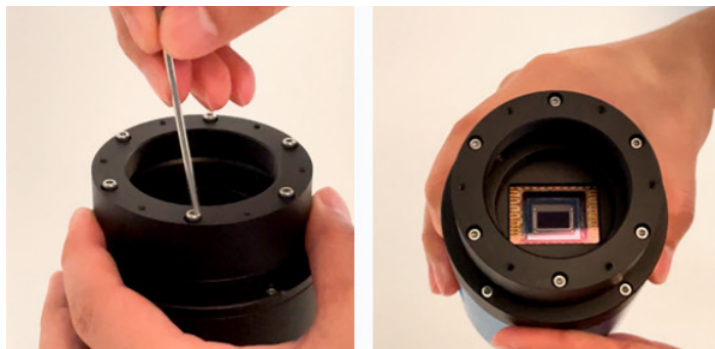

3.3 Connect OAG to extender

Locate the rest of the 6 screw holes on the extender and insert the 6 M2.5*6 screws through the OAG inner 6 screw holes and insert them into the screw holes on the extender, that has already been connected to camera.

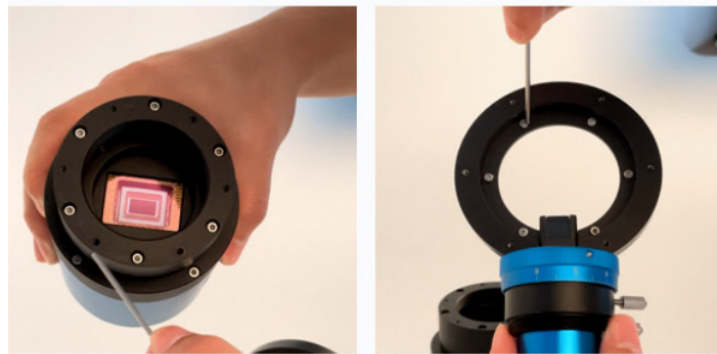

Tighten the screws to lock the OAG with the extender



3.4 Connect thread adapter (connect to telescope) to OAG

Locate the rest of the 6 screw holes on OAG and insert the 6 M2.5*6 screws through the thread adapter screw holes and insert them into the screw holes on OAG.



Tighten the screws to lock the thread adapter with OAG.

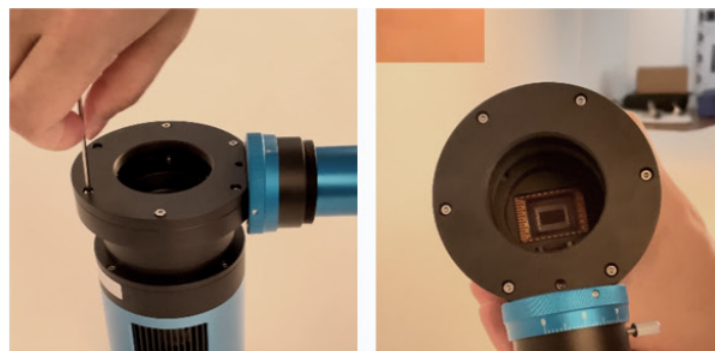

3.5 Adjust prism position

Make sure the prism in the OAG does not block the sensor. Loosen the screw in the top middle of the OAG to loosen the prism, then the prism can be moved up and down. Find the proper position for the prism then tighten the top middle screw again to lock the prism.

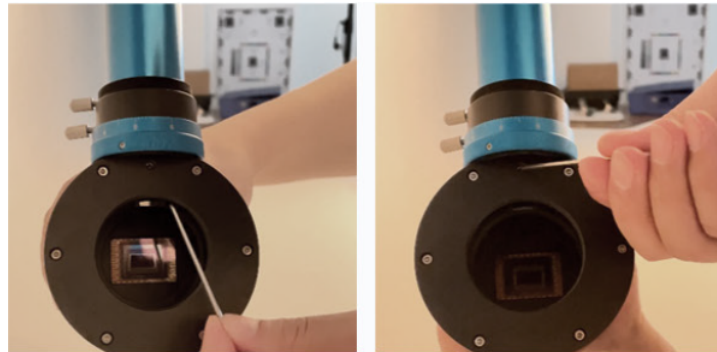

Make sure to tighten every screw mentioned above to prevent light leak.



Figure 3 complete connection between OAG and color camera

3.6 Focus adjustment

In order to focus the guiding camera properly, the user can adjust the prism position up or down, and also pull or push the guiding camera. ToupTek OAG also has a built-in helical focuser with 6mm adjustable distance. The user can rotate the blue dial to adjust the focus distance and once a proper position is found, the user simply tightens the screw on the blue dial to lock the position.

4 ToupTek OAG Mechanical Diagram

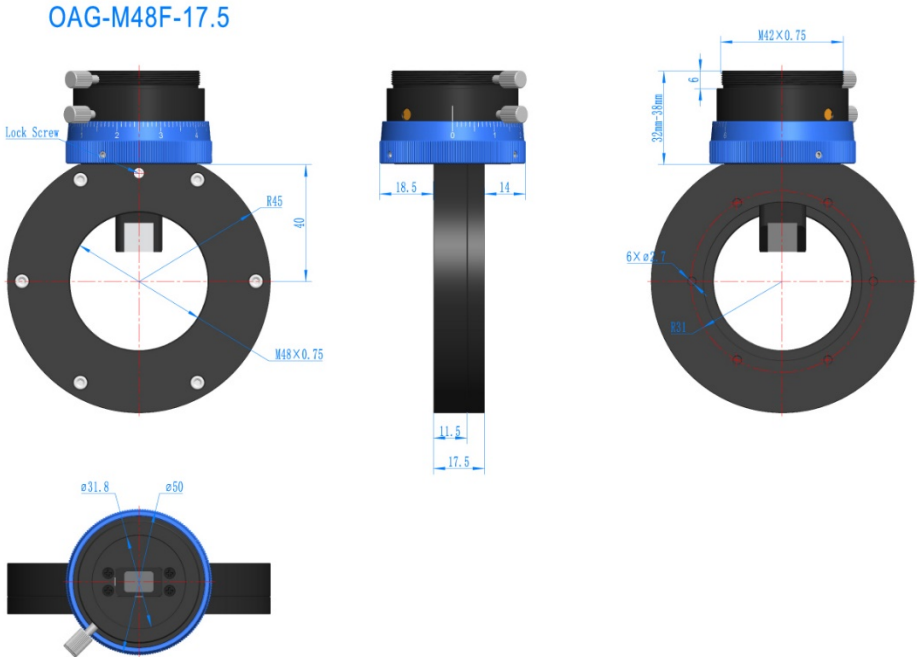

Figure 4 OAG with M48 thread adapter

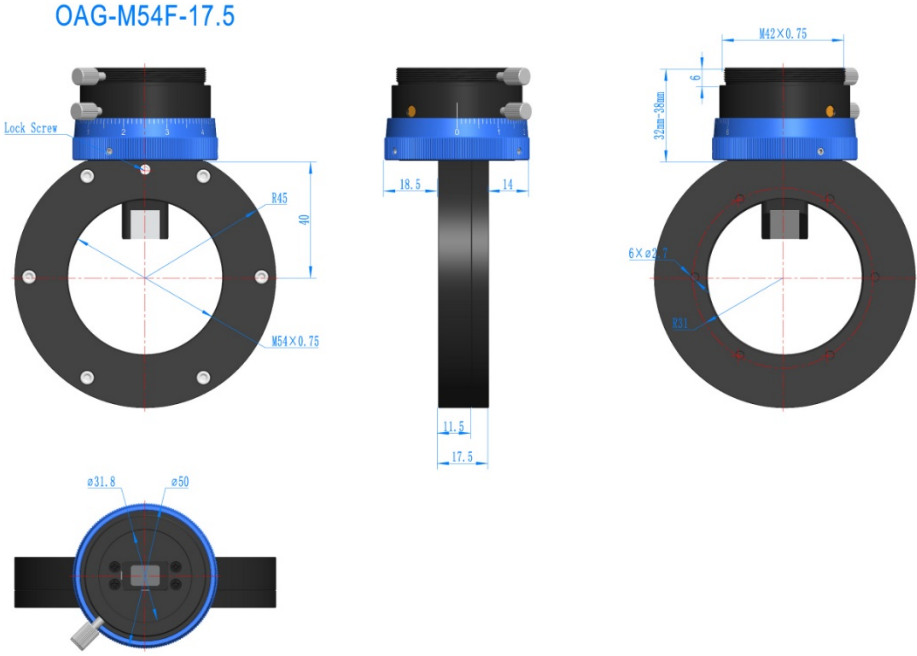

Figure 5 OAG with M54 thread adapter

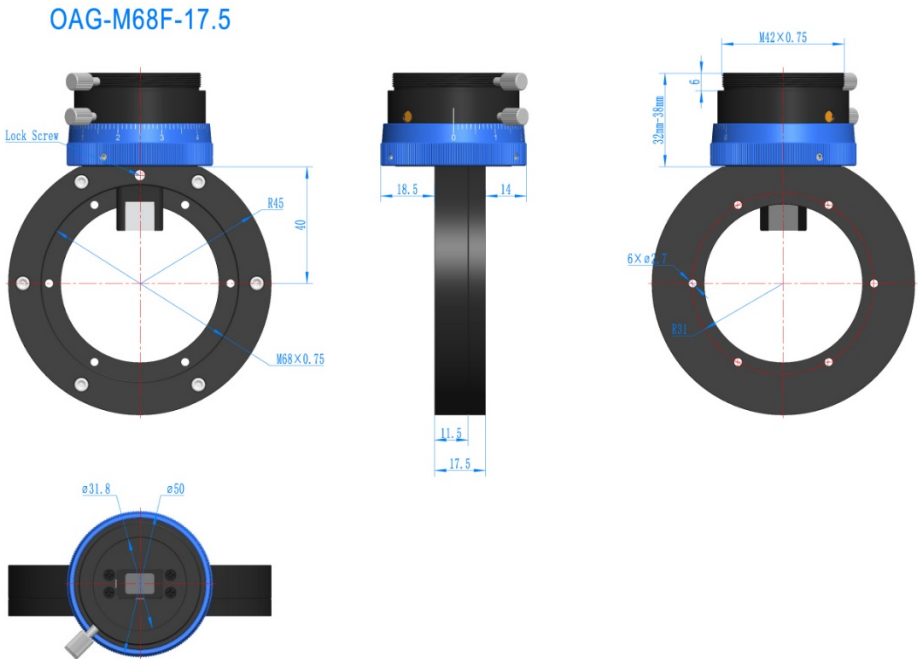
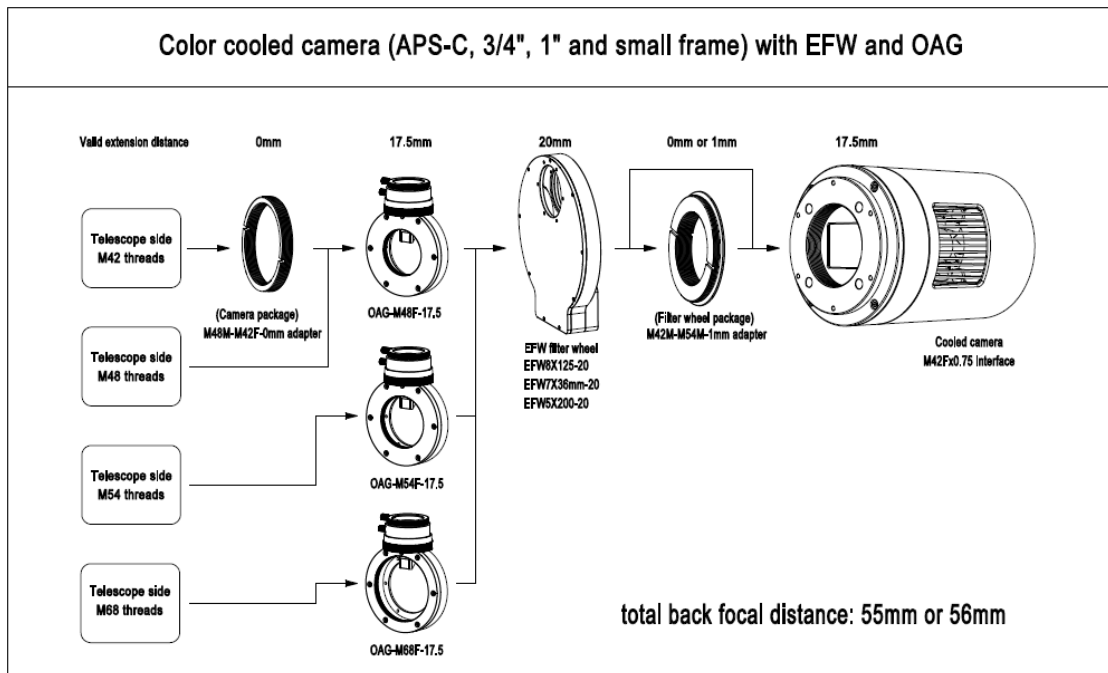
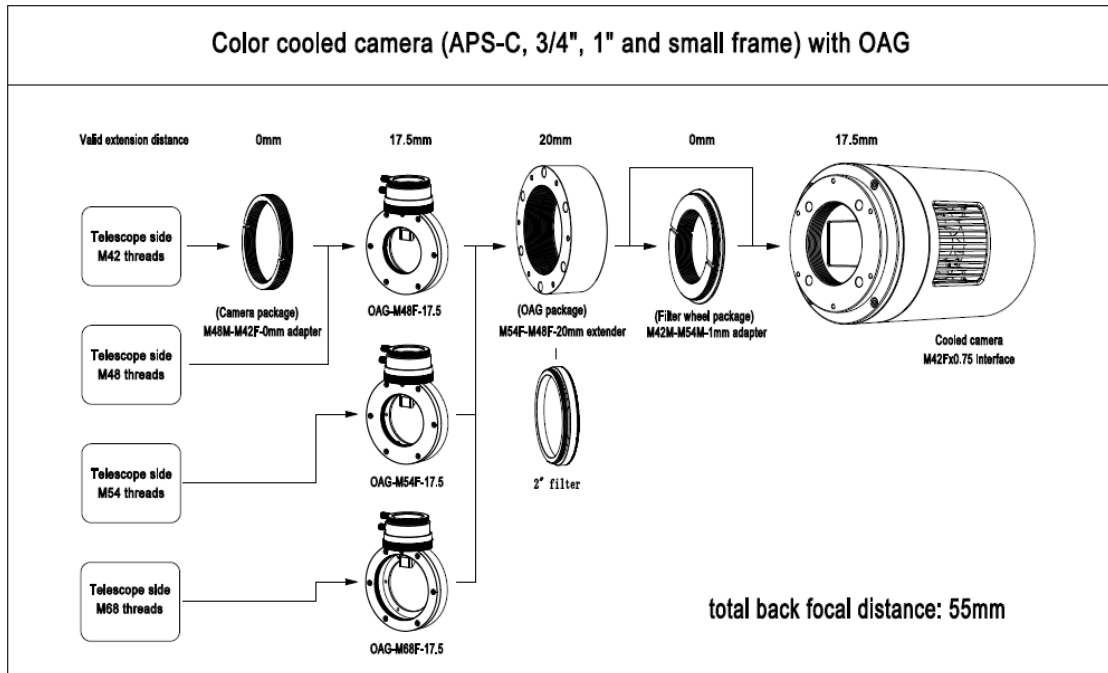
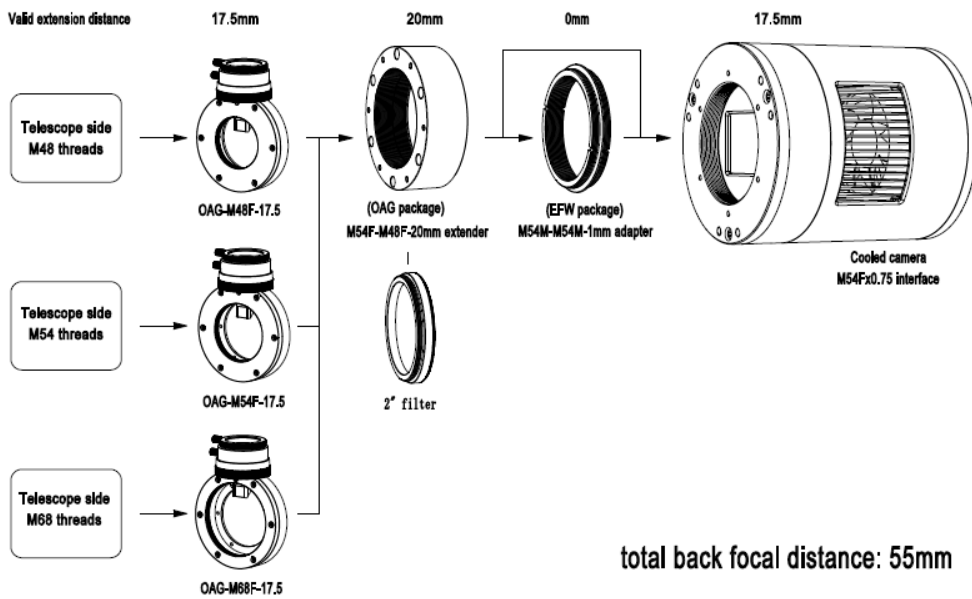

Figure 6 OAG with M68 thread adapter

5 ToupTek OAG recommended Connection methods



Color cooled camera (full frame) with OAG



Color cooled camera (full frame) with OAG and EFW

