

GPM174M User Manual

Version 1.0

Jan 2025



All materials related to this publication are subject to change without notice and its copyright totally belongs to ToupTek Photonics.

Please download the latest version from touptek.com.

Contents

GPM174M User Manual	1
1 Description and Features.....	1
2 GPM174M Specifications and Performance	2
2.1 Camera Specifications	2
2.2 Sony IMX 249 Sensitivity	3
2.3 12bit ADC and ROI.....	3
2.4 Frame Buffer.....	3
2.5 Binning	4
2.6 Power and Cooling System for Precise Temperature Regulation.....	4
2.7 Camera Performance Analysis	4
3 Product Package and Connections	7
3.1 Packing List.....	7
3.2 Camera Dimension and Its Mount.....	8
3.3 Camera Outline and Interface.....	9
4 GPM174M and Its Software	10
4.1 Application Installation	10
4.1.1 <i>User-friendly UI Design</i>	10
4.1.2 <i>Professional Camera Control Panel</i>	12
4.1.3 <i>Practical Functions with Good Results</i>	12
4.1.4 <i>Powerful Compatibility</i>	13
4.1.5 <i>Hardware Requirement</i>	13
4.2 GPM174M and Dshow.....	13
4.3 GPM174M and the 3 rd Party Software	13
4.3.1 <i>Support Software</i>	13
4.3.2 <i>ASCOM Platform</i>	14
4.3.3 <i>PHD Guiding</i>	14
4.3.4 <i>Nebulosity</i>	14
4.3.5 <i>MetaGuide</i>	14
4.3.6 <i>MAXIMDL</i>	14
4.3.7 <i>AstroArt</i>	14

<i>4.3.8 FireCapture</i>	<i>14</i>
<i>4.3.9 SharpCAP</i>	<i>14</i>
<i>4.3.10 Registax</i>	<i>14</i>
<i>4.3.11 AstroStack</i>	<i>14</i>
<i>4.3.12 DeepSky Stacker</i>	<i>14</i>
5 Service	15

1 Description and Features

GPM174M camera possesses an exceptionally strong capability to capture faint signal (with a high QE value at 500nm). It also has a large sensor format, high full well capacity, high sensitivity, and low readout noise among other advantages. This results in outstanding performance in planetary photography, as well as in solar and lunar photography.

The features of GPM174M are listed below:

- IMX 249 Mono CMOS Sensor
- Resolution: 1920 x 1200
- 5.86 um Square Pixels
- 1/1.2-inch Optical Format
- 12-bit ADC
- Built-in Frame Buffer
- G Sensitivity: 825mv with 1/30s
- Low Noise: 3.96 to 6.48e-
- 18 FPS at all Pixel Readout 8 bit
- SNR Max: 45 dB
- Dynamic Range: 72.0 dB

2 GPM174M Specifications and Performance

2.1 Camera Specifications

Table 1 GPM174M Technique Specifications.

Sensor	Sony IMX 249 back illuminated sensor	
Diagonal	13.31 mm	
Image Resolution	2.3 mega pixels (1920*1200)	
Pixel Size	5.86 μ m \times 5.86 μ m	
Image Area	11.3mm \times 7.03mm	
Max FPS at Resolution	12bit	8bit
	8.5 FPS @ 1920*1200	16.2 FPS @ 1920*1200
Shutter Type	Global shutter	
Exposure Time	0.42ms – 1000s	
Gain	1x – 480x	
SNR	45 dB	
Dynamic Range	72.0 dB	
Read Noise	6.48 – 3.96 e-	
QE Peak	>89%	
Full Well	33.4ke-	
ADC	12bit	
Frame Buffer	Built-in	
Connection Port	USB2.0 Type C	
Camera Adaptor	Standard 1.25" for telescope connection, and standard C adapter for industrial lens	
Protect Windows	IR-cut filter/AR-window	
Spectral Range	380-1100nm (with AR protect window)	
Capture/Control SDK	Windows/Linux/macOS/Android Multiple Platform SDK(Native C/C++, C#/VB.NET, Python, Java, DirectShow, Twain, etc.);	
Recording System	Still picture and movie	
Camera Dimensions	Diameter 37mm * height 72.4mm	
Camera Weight	70 gram	
Back Focus Distance	Back Focus Distance is 8.5mm, 17.5mm with C adapter, 12.5 with CS adapter	
Cooling:	Passive cooling	
Supported OS	Microsoft® Windows® XP / Vista / 7 / 8 /10 (32 & 64 bit) OSx(Mac OS X)	

Linux

2.2 Sony IMX 249 Sensitivity

The sensor G Sensitivity of GPM174M is 825mv with 1/30s. Its spectral sensitivity is shown in Figure 1. The sensitivity is measured with a excitation LED light source with a color temperature of 3200 K, an IR cut filter CM500(t=1.0 mm) is placed between the LED light source and the sensor receiving surface to irradiate substantially parallel light.

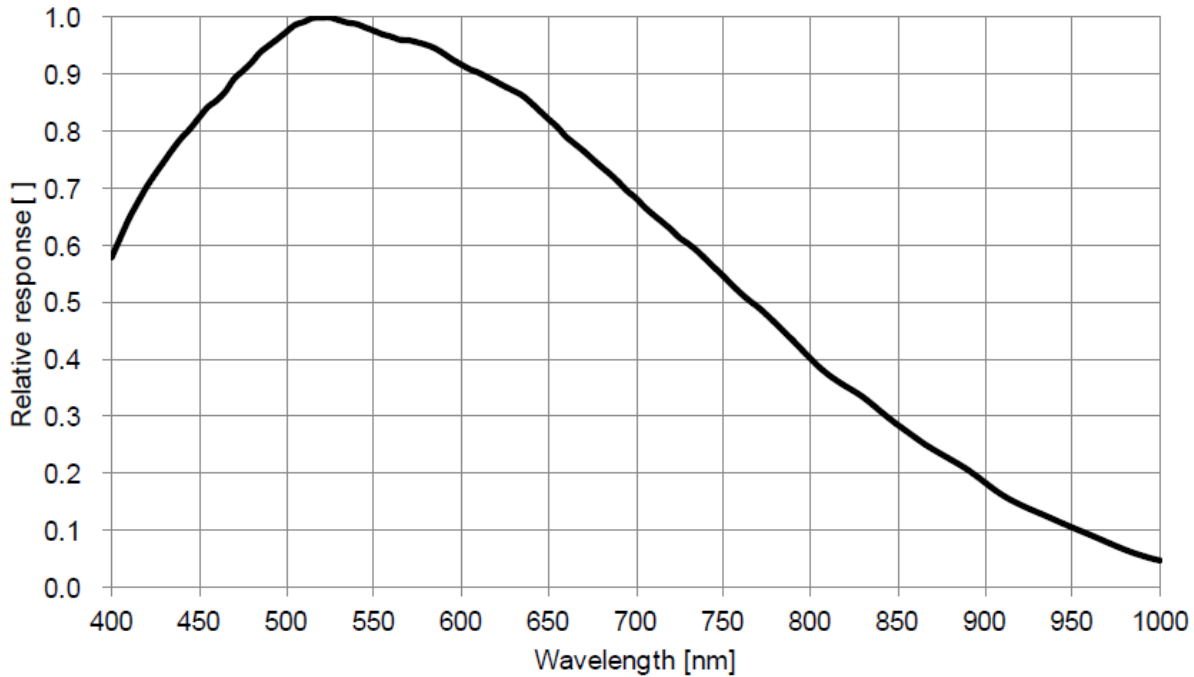

Figure 1 IMX 249 Spectral Sensitivity Characteristic

2.3 12bit ADC and ROI

GPM174M has built in 12bit ADC. It also has 12bit output mode for hardware binning and smaller resolution. The camera also supports hardware ROI, and the smaller the ROI size is, the higher the frame rate is.

Table 2 shows the frame rate of GPM174M in 12/8bit mode, USB2.0 data transfer interface at different resolutions:

Table 2 GPM174M Frame Rate at Different Resolution/Data Bit/Data Transfer (USB2.0)

Resolution	Bit & Interface	
	12bit ADC	8bit ADC
1920*1200	8.5	16.2

2.4 Frame Buffer

GPM174M camera has a built-in frame buffer, which helps maintain the stability of data transmission, and effectively reduce the amp-glow caused because image data can be temporarily buffered without being sent hastily to the receiver. Ensure

that each camera can still achieve its maximum frame rate when multiple cameras are operating simultaneously.

2.5 Binning

GPM174M supports software to digital binning from 1×1 to 8×8 in either stacking or averaging method.

2.6 Power and Cooling System for Precise Temperature Regulation

The camera operates via a USB 2.0 interface. Upon establishing a connection with the host system using the USB 2.0 cable, the device is primed for operation.

2.7 Camera Performance Analysis

Camera performance can be evaluated with [e-/ADU](#), [Read Noise](#), [Full Well](#) and [Dynamic Range](#).

e-/ADU: The sensors found in cameras used for vision applications have pixels that convert incoming photons into electrons. Gain on a CCD/CMOS camera represents the conversion factor from electrons (e-) into digital counts, or [Analog-Digital Units \(ADUs\)](#). Gain is expressed as the number of electrons that get converted into a digital number, or electrons per ADU ([e-/ADU](#)).

Read Noise: Read Noise is the most important reference to measure the performance of a camera. Lower read noise usually means better SNR and better quality of image. [Read Noise](#) is created within the camera electronics during the readout process as the electrons are subjected to the analog to digital conversion, amplification and processing steps that enable an image to be produced.

Full Well: The electrons are held in each pixel and are converted into electrical charge which can be measured to show the amount of light that has fallen on each pixel. The maximum electrical charge possible is termed "[full well capacity](#)". Under the same conditions such as noise and A/D converter quality, the greater full well capacity a sensor has, the wider dynamic range the sensor has. As there is a limit to the depth to which pixels can be made, the full well capacity is often proportional to the frontal area of the light gathering element of the pixel.

Dynamic Range is the ratio between the maximum output signal level and the noise floor at minimum signal amplification (noise floor which is the RMS (root mean square) noise level in a black image). The noise floor of the camera contains sensor readout noise, camera processing noise and the dark current shot noise. [Dynamic range](#) represents the camera's ability to display/reproduce the brightest and darkest portions of the image and how many variations in between. This is technically intra-scene dynamic range. Within one image there may be a portion that is in complete black and a portion that is completely saturated.

For the GPM series camera, the [Gain Value](#) is in xxx% mode. Here xxx is used as the x axis ([Gain Value](#)) for the description of the camera performance

$$Rel\ Gain(dB) = 20 * \log_{10}[xxx(Gain\ Value)/100]$$

$$xxx(Gain\ Value) = 100 \times 10^{(Rel\ Gain(dB)/20)}$$

Read noise is the most important reference to measure the performance of a camera. Lower read noise usually means better SNR and better quality of image.

Camera setting used for performance analysis is shown below:

- Full resolution
- RAW 12-bit mode

Figure 2 shows the curves of the camera analysis data in Table 3

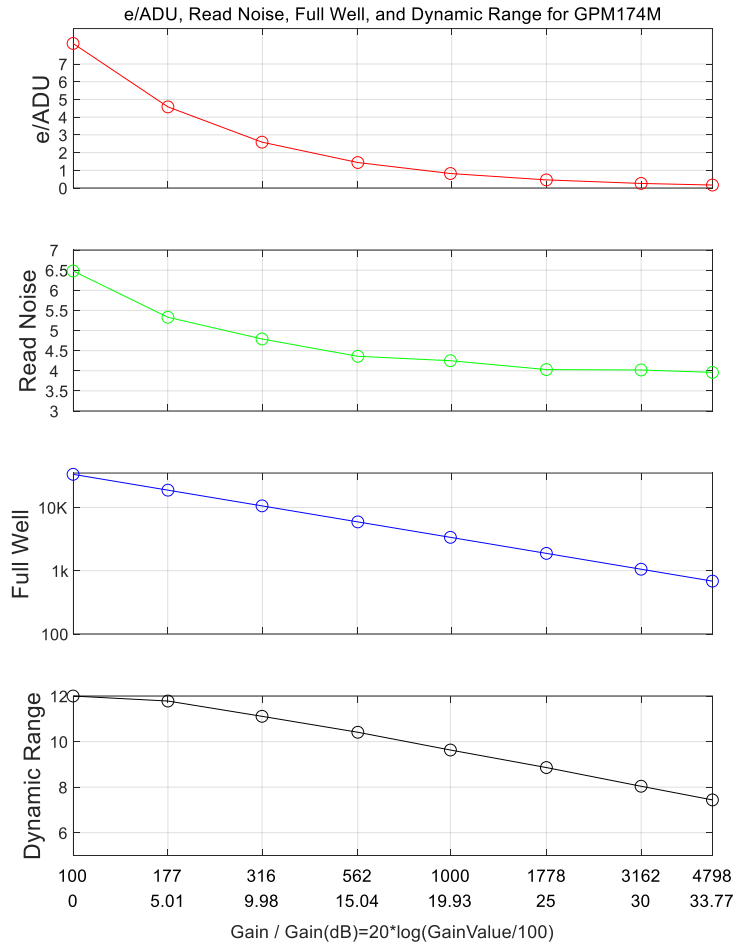

Figure 2 e-/ADU, Read Noise, Full Well and Dynamic Range for GPM174M

The camera analysis data is shown in Table 3:

Table 3 Camera Analysis Data

Sensor Analysis Data								
Gain Value	100	177	316	562	1000	1778	3162	4798
Rel Gain (dB)	0.00	5.01	9.98	15.04	19.93	25.00	30.00	33.77
e-/ADU	8.16	4.58	2.59	1.44	0.82	0.46	0.26	0.17
Read Noise (e-)	6.48	5.33	4.79	4.36	4.25	4.03	4.02	3.96

Full Well (ke-)	33.43	18.77	10.59	5.92	3.37	1.88	1.06	0.68
Dynamic Range (stop)	12	11.78	11.11	10.41	9.63	8.86	8.04	7.44

3 Product Package and Connections

3.1 Packing List



Figure 3 Packing Information of GPM174M

Table 4 GPM174M Packing List

Standard Camera Packing List	
A	Carton L:50cm W:30cm H:30cm (20pcs, 12~17Kg/ carton, 0.045m ³), not shown in the photo
B	Gift box L:15cm W:15cm H:10cm (0.8~1.0Kg/ box)
C	One GPM series camera with a Type-C-Mount(inner)
D	High-speed USB3.0 A male to C male connectors cable /2.0m
F	1.25-inch nosepiece
G	ST4 guide cable /2.0m
H	CS-mount ring

3.2 Camera Dimension and Its Mount

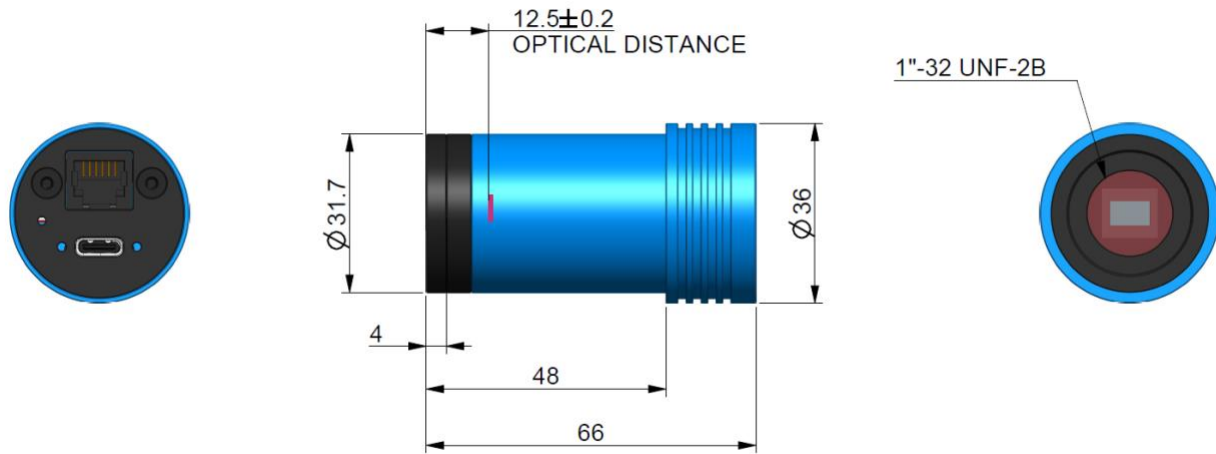

Figure 4 Dimension and Mount of GPM174M and 1.25" extender

The GPM series body, made from tough, alloy, ensures a heavy duty, workhorse solution. The camera is designed with a high-quality IR-CUT or AR to protect the camera sensor and block the IR elimination the reflection light. No moving parts included. These measures ensure a rugged, robust solution with an increased lifespan when compared to other industrial camera solutions.

Table 5 Adapter of GPM174M

Item	Specification
1	Directly with 1.25" telescope;
2	GPM + 1.25" extender with 1.25" telescope
3	Standard C adapter connects to industrial C-mount adapter lens.

3.3 Camera Outline and Interface



Figure 5 Camera Outline and Interface.

Table 6 Camera Outline and Interface List

Item	Specification
1	A built-in ST4 auto guider port for the easy connection of the auto guider.
2	USB2.0 interface, Type C

4 GPM174M and Its Software

4.1 Application Installation

For software, customers are welcomed to go to our software website: <https://touptek-astro.cn>, to download the latest ToupSky. The GPM can also be used with ASCOM, DirectShow SDK. If the third-party software is compatible with these SDK, customers can also download the software driver from our website and install the drivers into the third-party software.

ToupSky is ToupTek astronomy camera's Windows application. ToupSky is a professional software integrated with camera control, image capture & process, image browse, and analysis functions. ToupSky is born with the following features:

Windows:

- x86: XP SP3 or above; CPU supports SSE2 instruction set or above
- x64: Win7 or above

Features

- Full control of the camera
- Trigger mode and video mode support (raw format or RGB format)
- Automatic capture and quick record function
- Multi-language support
- Hardware ROI and digital binning function
- Extensive image processing functions, like image stitching, live stacking, flat field correction, dark field correction, etc.

Supported Camera:

- All ToupTek astronomy cameras

4.1.1 User-friendly UI Design

- Well-arranged menus and toolbars ensure quick operating;
- The unique design of 3 sidebars -- **Camera**, **Folders**, **Undo/Redo** are orderly classified;
- Convenient operating method (Double click or right-click context menu) as much as possible;
- Detailed help manual;

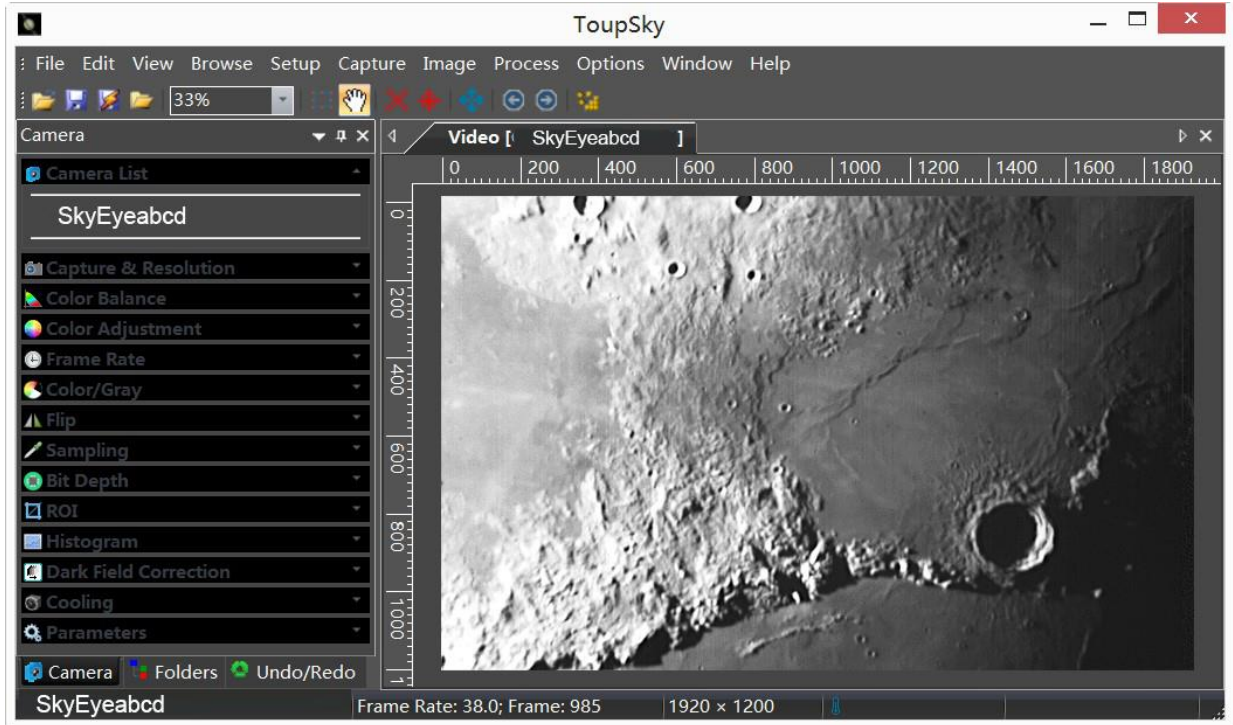

Figure 6 ToupSky and Its Video Window

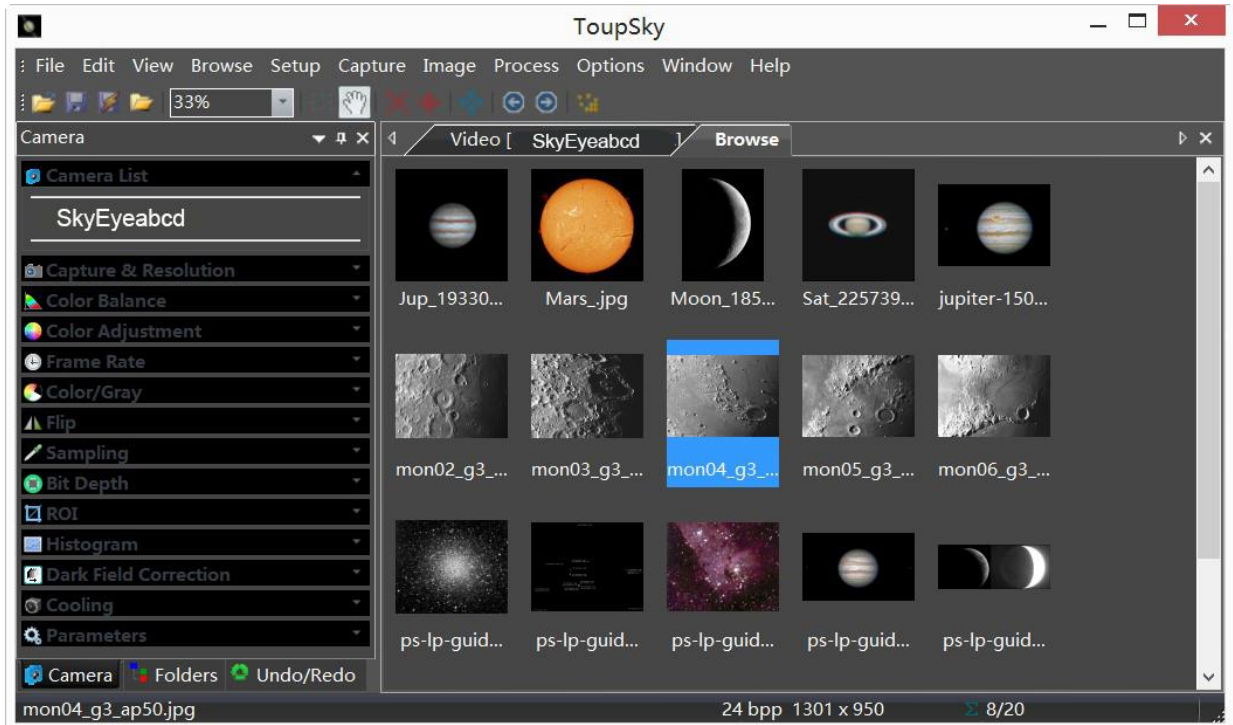

Figure 7 ToupSky and Its Browse Window

4.1.2 Professional Camera Control Panel

Capture & Resolution	Set the live and snap resolution and snap the image or record video;
Exposure & Gain	Auto exposure (exposure target preset) and manual exposure (exposure time can be inputted manually); Up to 5 times gain;
Color Balance	Advanced single-click intelligent white balance setting, temperature and tint can be manually adjusted;
Color Adjustment	Hue, saturation, brightness, contrast, gamma initialization adjustment;
Frame Rate	Adjustment of frame rate available for different computer configurations;
Flip	Check the "horizontal" or "vertical" option to correct the sample direction;
Sampling	Bin mode can obtain low noise video stream; Skip mode obtains sharper and smoother video stream. Support video stream histogram extension, Negative and positive switching, Gray calibration, Clarity factor for focusing etc.
Bit Depth	Switch between 8 bits and 12 bits. 8 bits is the basic Windows image format. 12bits will have higher image quality but moderate FPS.
ROI	ROI, Region of interest. This function can set the ROI on the video window. When the ROI group was expanded, a dotted rectangle with "Handles" will appear around the video window that will let you alter the ROI. Use mouse button to adjust the ROI size. If ROI is ok, click Apply will set the video to ROI size, Defaults will return to the original size.
Dark Field Correction	To Enable the Dark Field Correction, one should capture the dark field image first. After the images are captured, the Enable button will be clickable. Checking the Enable button will enable the Dark Field correction. Unchecking it will disable the Dark Field Correction.
Cooling	Set the TE-Cooling target temperature and set the fan On/Off;
Parameters	Load, save, overwrite, import, export self-defined parameters of camera control panel (including calibration information, exposure and color setting information);

4.1.3 Practical Functions with Good Results

Video functions	Various professional functions: Video broadcast; Time lapse capture; Video record; Video stream grid; Image stitch; Video scale bar, date etc.
Image Processing and Enhancement	Control and adjust image by denoise, sharpen, color toning deinterlace, all kinds of filtering algorithm and mathematical morphology algorithm, range, binary, pseudo color, surface plot and line profile ital..
Image Stacking	Image stacking adopts advanced image matching technology. With the recorded video, regardless of shifting, rotation, scaling, the high-fidelity image can be stacked to decrease the image noise.

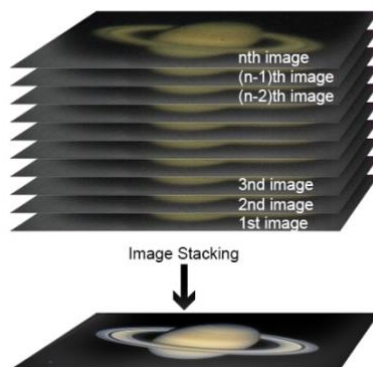

Figure 8 Image Stacking

4.1.4 Powerful Compatibility

Video Interface	Support Twain, DirectShow, SDK Package (Native C++、C#/VB.NET)
Operating System	Compatible with Microsoft® Windows® XP / Vista / 7 / 8 /10 (32 & 64 bit), Mac OSX, Linux
Language Support	Unlimited language support, currently available in Simplified Chinese, Traditional Chinese, English, Russian, German, French, Polish and Turkish

4.1.5 Hardware Requirement

PC Requirements	CPU: Intel Core 2 2.8GHz or higher
	Memory:2GB or more
	USB port: USB3.0/USB2.0 port
	Display:17" or larger
	CD-ROM

4.2 GPM174M and Dshow

ToupTekDshowAstroSetup (Click the left blue link to download)

DshowAstro is an interface driver providing Dshow standard support for ToupTek USB astronomy camera

Supported OS: Windows:

- x86: XP SP3 or above; CPU supports SSE2 instruction set or above
- x64: Win7 or above

Supported Camera:

- All ToupTek astronomy cameras

4.3 GPM174M and the 3rd Party Software

4.3.1 Support Software

No.	Software	Version	WDM	ASCOM	Native
1	PHD Guiding	2.3.0(2014)	√	√	√
2	Nebulosity	3.2.2(2014)	√	×	/
3	MaxIm DL	5.23(2013)	√	×	/
4	SharpCap	2.1(2014)	√	×	/
5	MetaGuide	5.2.0(2014)	√	/	/
6	FireCapture	2.4.05(2014)	√	/	/
7	Astroart	5.0(2014)	√	×	/

4.3.2 ASCOM Platform

All AstroCam telescope camera drivers request to install ASCOM platform, free.

<http://www.ascom-standards.org/index.htm>

You can download the ASCOM package from : <http://ascom-standards.org/Downloads/Index.htm>

4.3.3 PHD Guiding

A popular free guide software: <http://openphdguiding.org/>

ToupTek's telescope camera support Native/ASCOM/WDM driver to run the video.

4.3.4 Nebulosity

A popular cooled camera control/image process software directly supported via ASCOM.

4.3.5 MetaGuide

Autoguiding software with novel method to avoid the atmospheric agitation. The latest version support GCMOS01200KPB and the guide port: <http://www.astrogeeks.com/Bliss/MetaGuide/>

4.3.6 MAXIMDL

Famous full functional CCD Control/Image Process software. Popular used in US.

4.3.7 AstroArt

Famous full functional CCD Control/Image Process software. Popular used in Europe.

4.3.8 FireCapture

Great free planetary capture software. Support part of AstroCam series telescope camera.

4.3.9 SharpCAP

A nice free planetary capture software support WDM cameras includes AstroCam series telescope camera.

4.3.10 Registax

A popular free planetary stacking and processing software.

4.3.11 AstroStack

A planetary stacking and process software.

4.3.12 DeepSky Stacker

A free deep sky image stack and process software.

5 Service

For software upgrades, please refer to “Download” on our official website: <https://ToupTek.com//>

For customers who purchase the cameras from local dealer, please contact your dealer for more inquiry.

For technical support, please contact e-mail address: astro@touptek.com.